

MCS-TOUCH-15.4IN-D

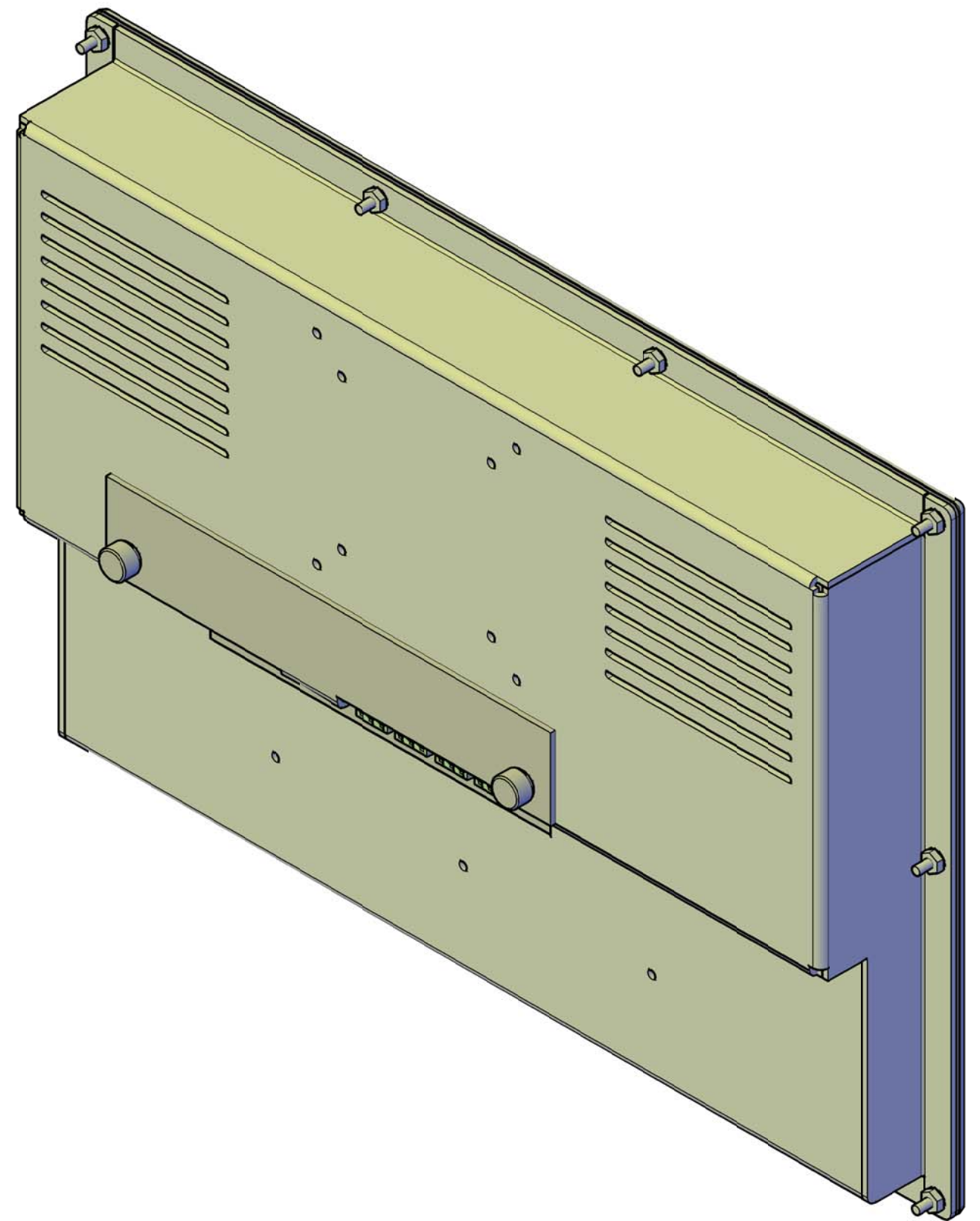

MCS-TOUCH-15.4IN-D

Disassembly MCS-TOUCH-15.4IN-D

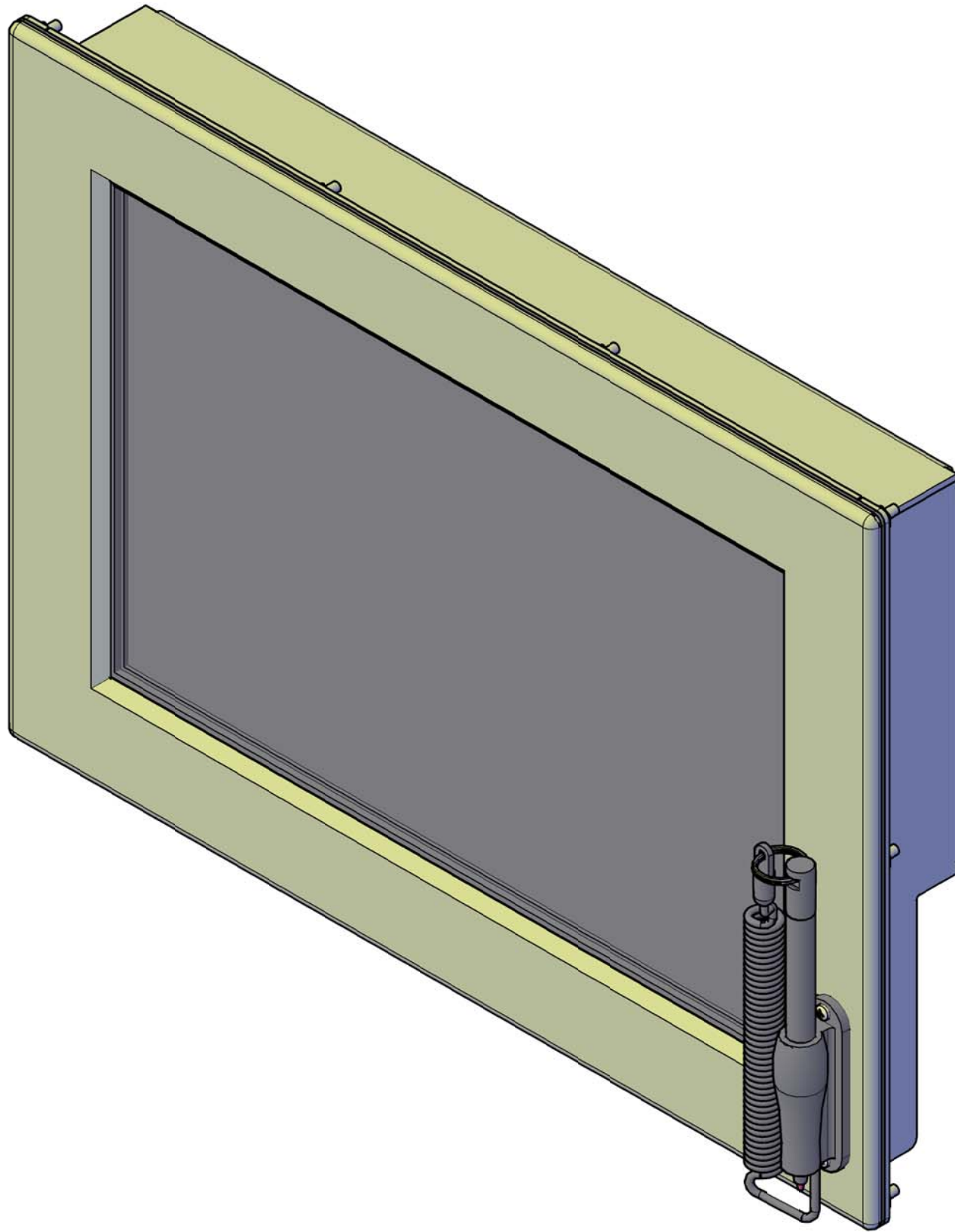
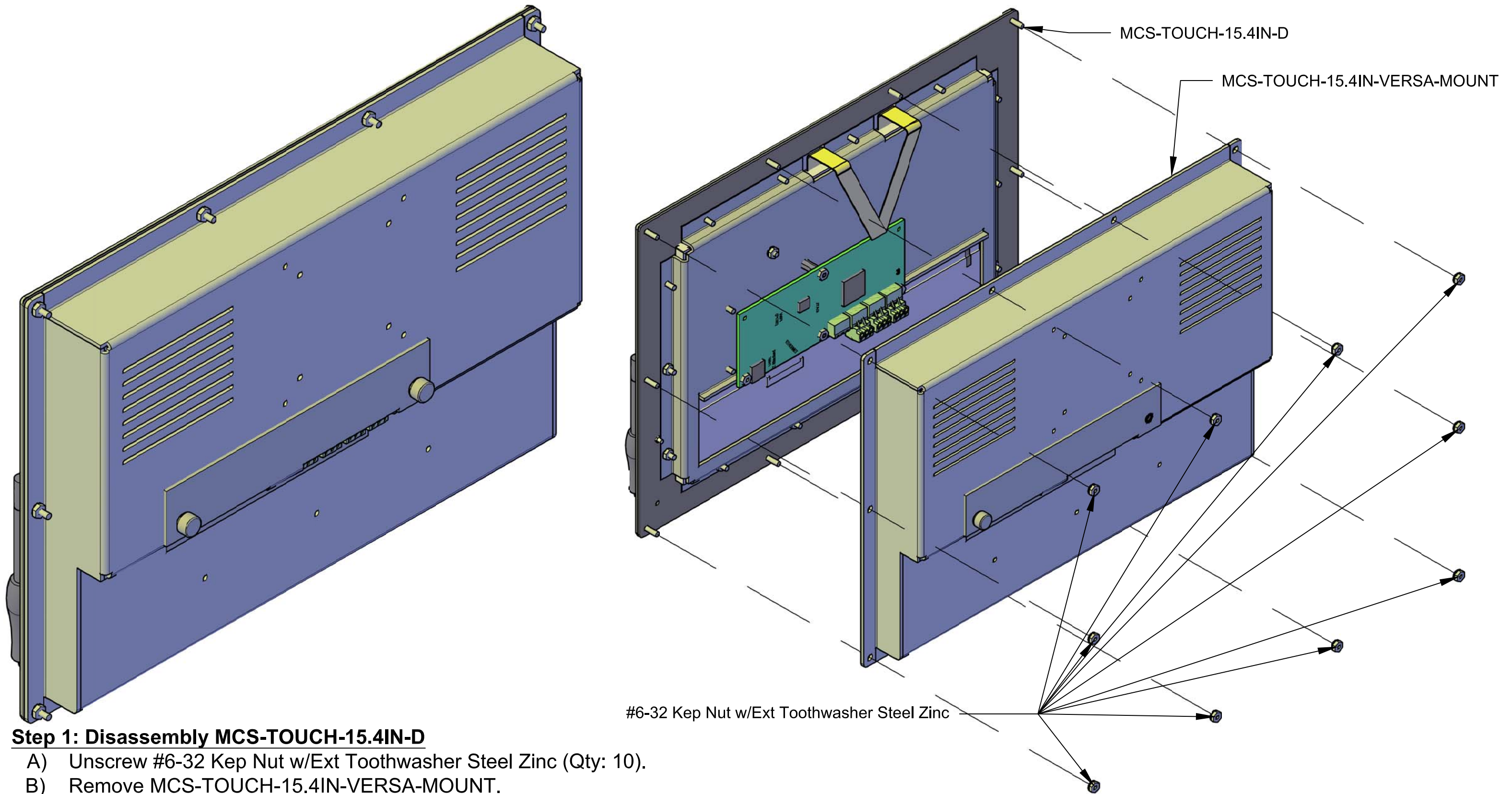

Step 1: Disassembly MCS-TOUCH-15.4IN-D

- A) Unscrew #6-32 Kep Nut w/Ext Toothwasher Steel Zinc (Qty: 10).
- B) Remove MCS-TOUCH-15.4IN-VERSA-MOUNT.

Customer Supplied Enclosure

Outline of
MCS-TOUCH-15.4IN-D

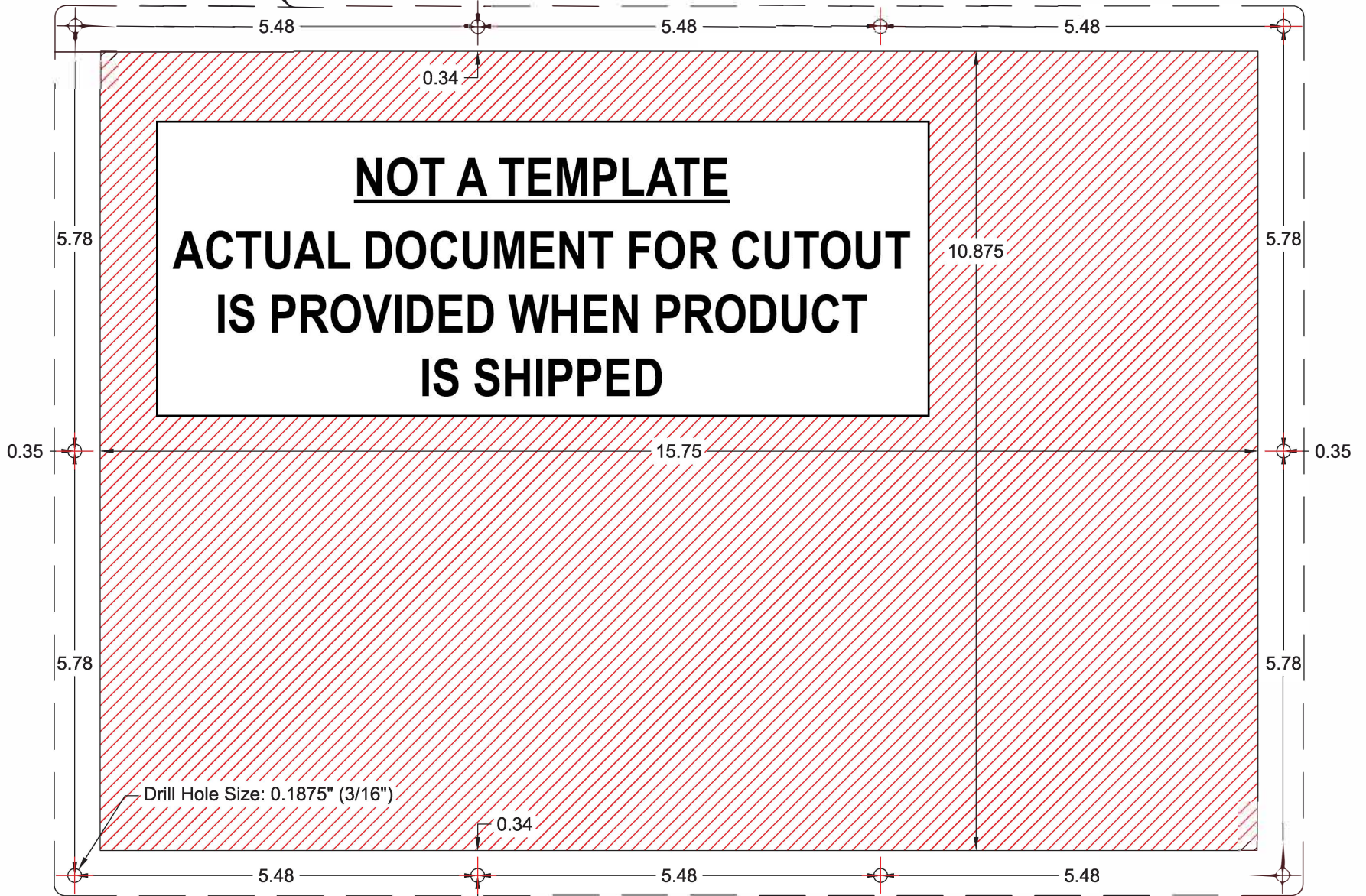

View: Front

Print Size: 17 x 22 (ANSI C)

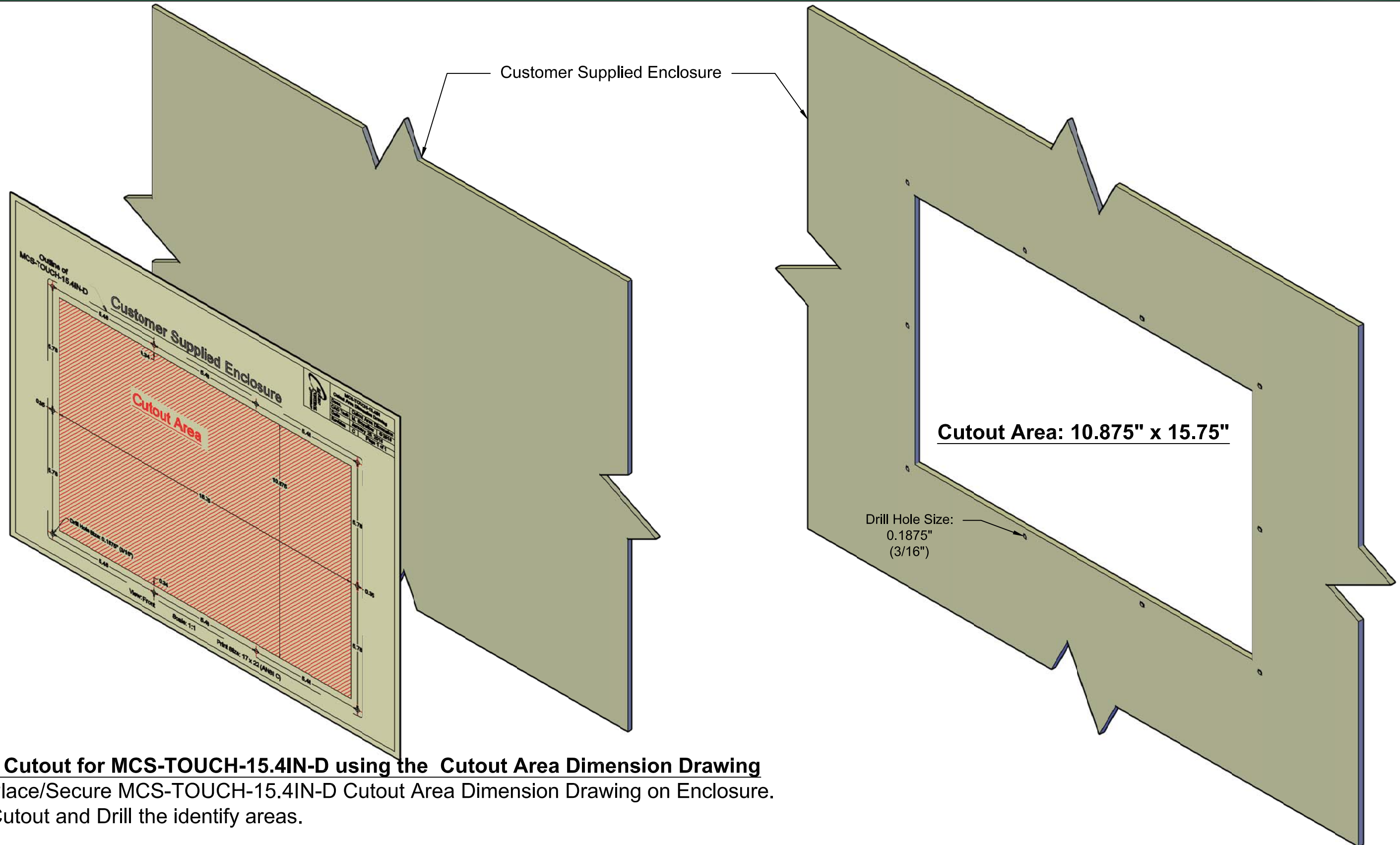

Step 2: Cutout for MCS-TOUCH-15.4IN-D using the Cutout Area Dimension Drawing

- A) Place/Secure MCS-TOUCH-15.4IN-D Cutout Area Dimension Drawing on Enclosure.
- B) Cutout and Drill the identify areas.

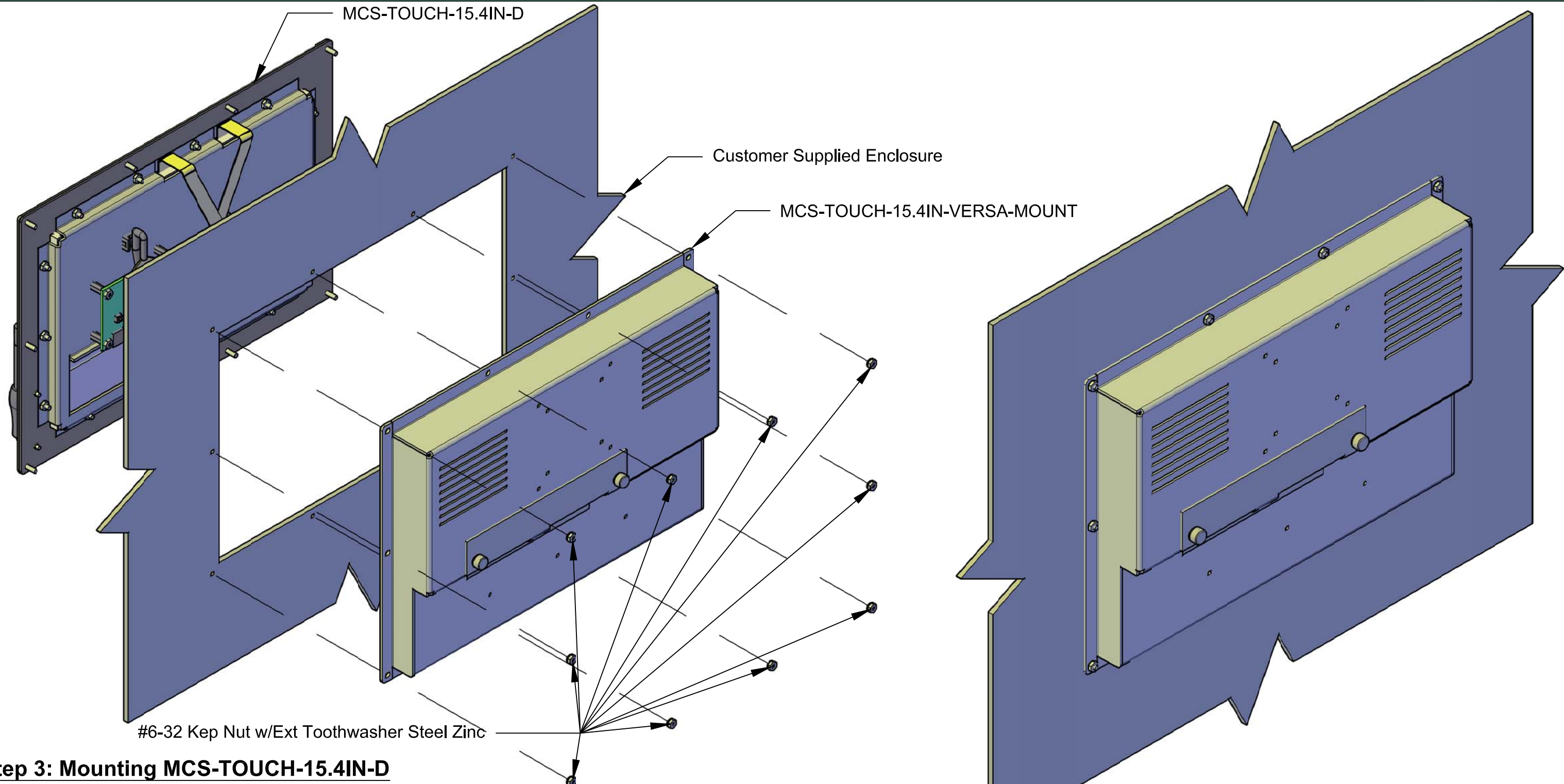

Step 3: Mounting MCS-TOUCH-15.4IN-D

- A) Place MCS-TOUCH-15.4IN-D inside Customer Supplied Enclosure.
- B) Mounted MCS-TOUCH-15.4IN-VERSA-MOUNT to MCS-TOUCH-15.4IN-D.
- C) Secure MCS-TOUCH-15.4IN-D and MCS-TOUCH-15.4IN-VERSA-MOUNT with #6-32 Kep Nut w/Ext Toothwasher Steel Zinc (Qty: 10).

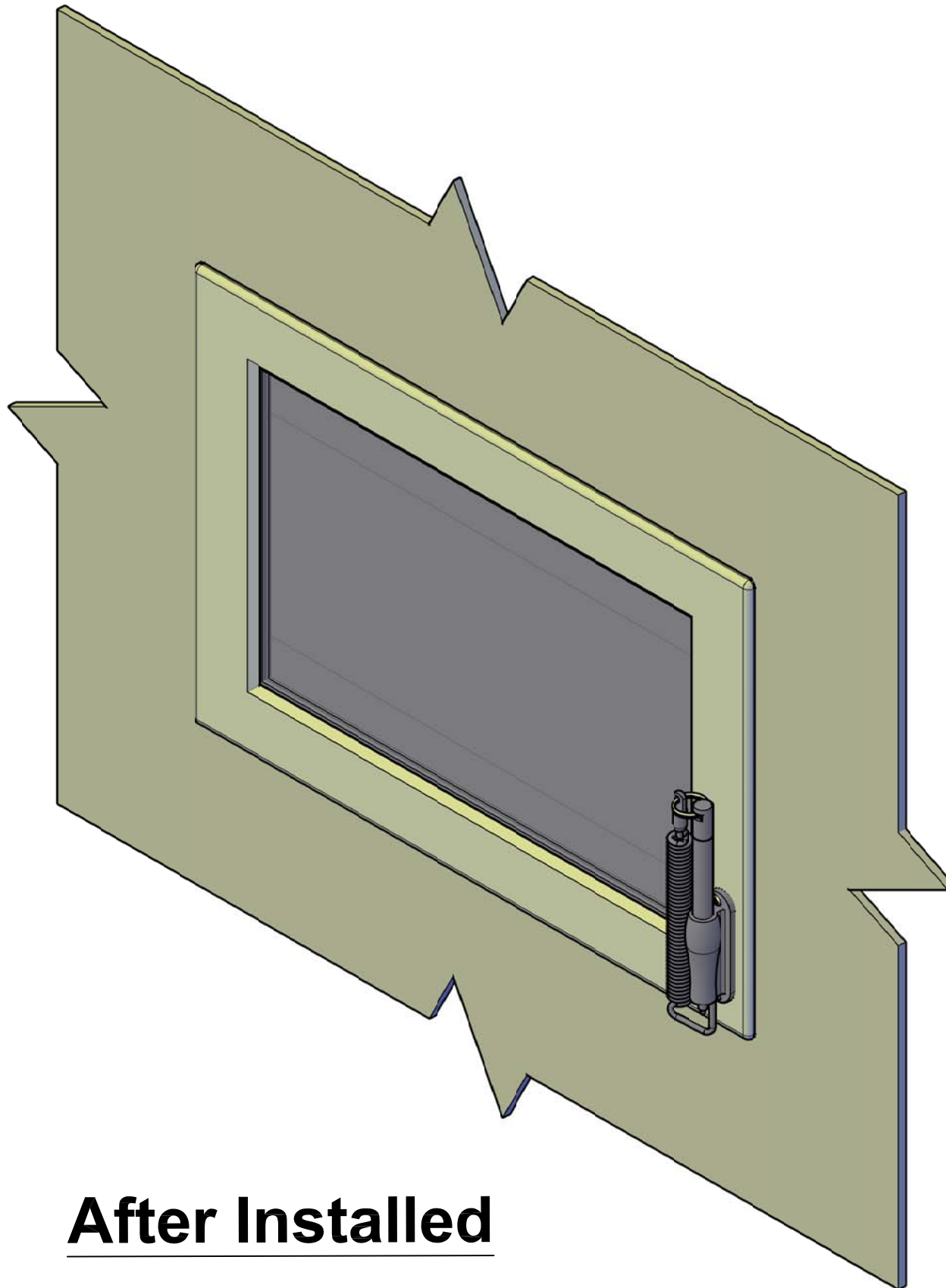

After Installed

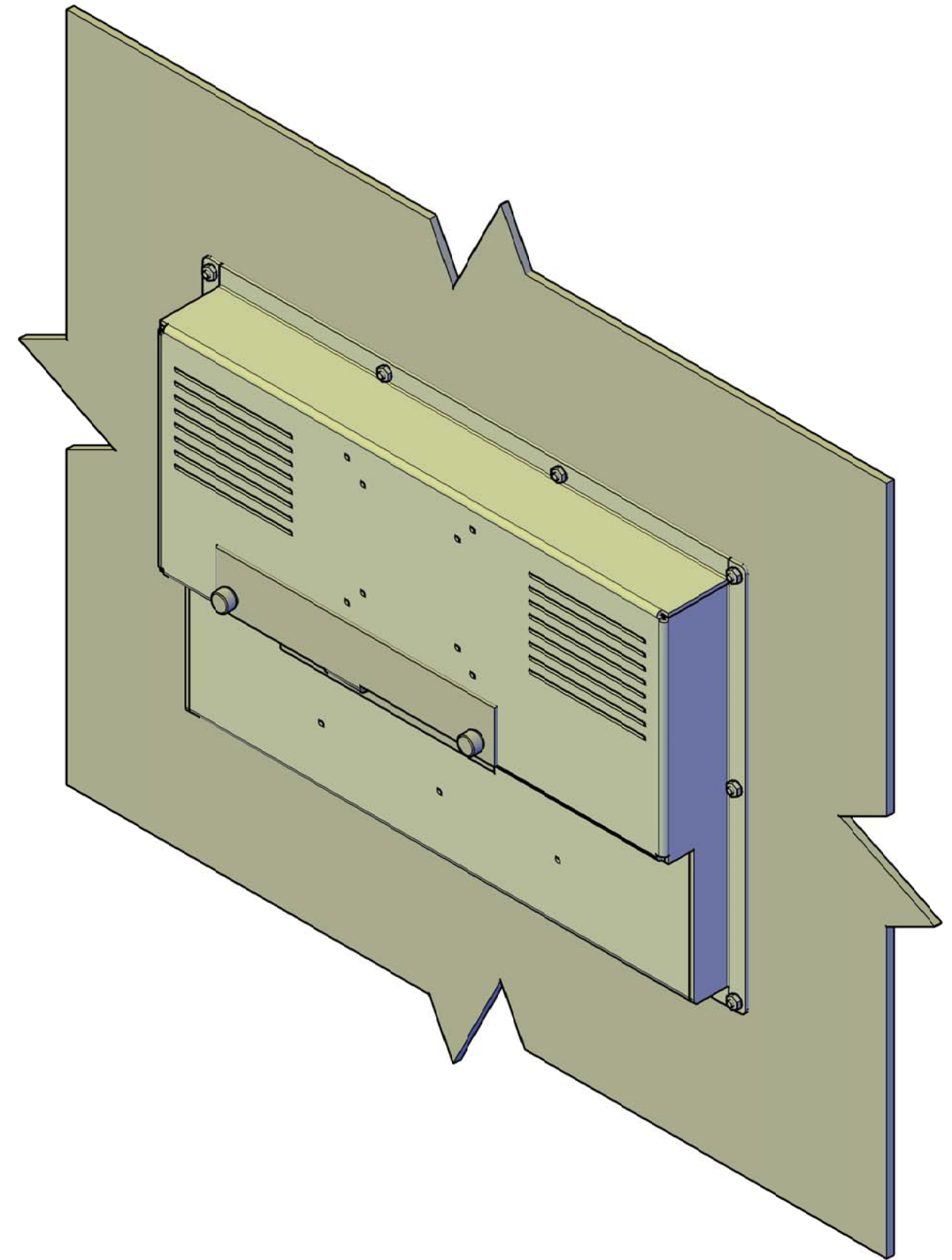

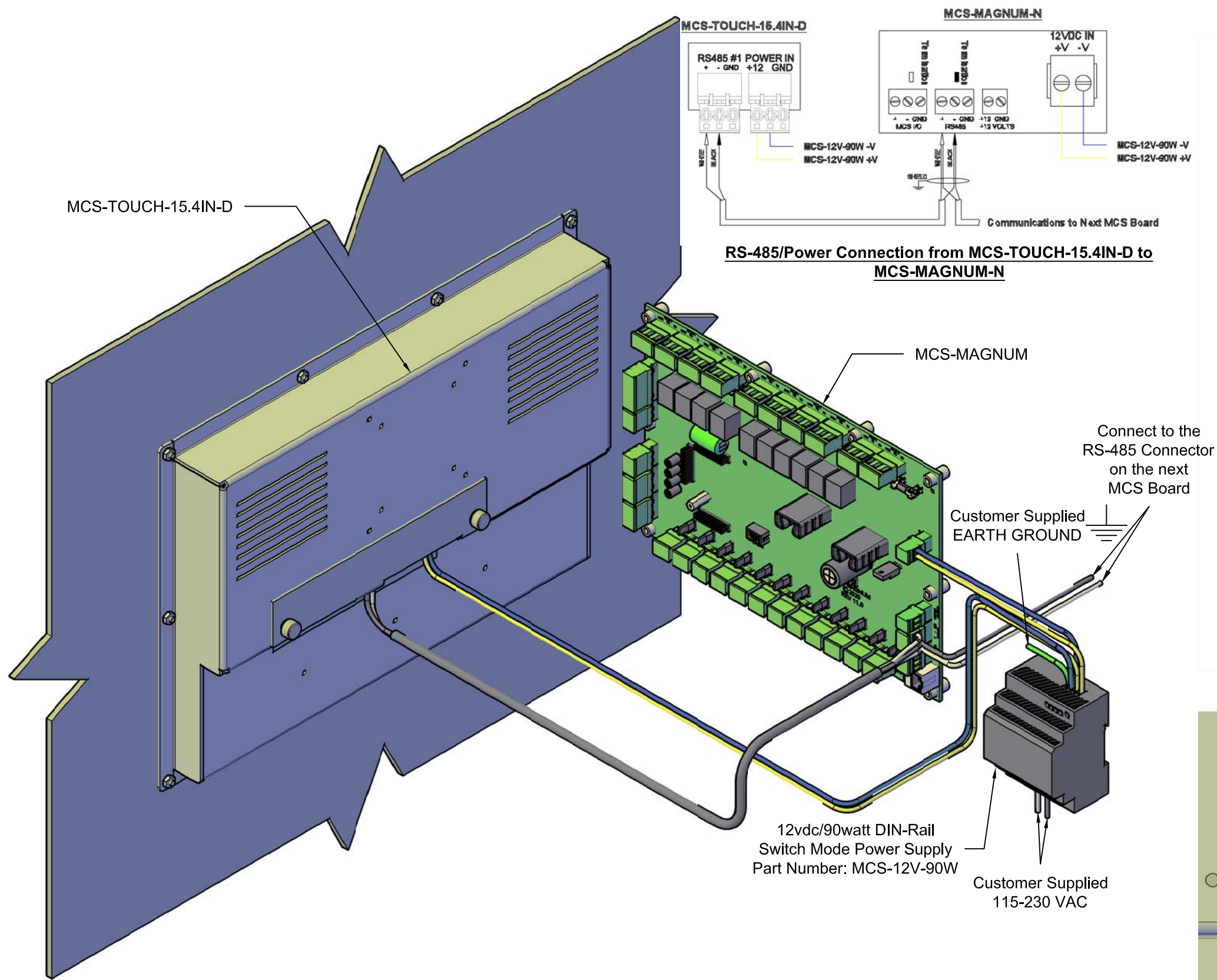

MCS-12V-90W Wiring Diagram

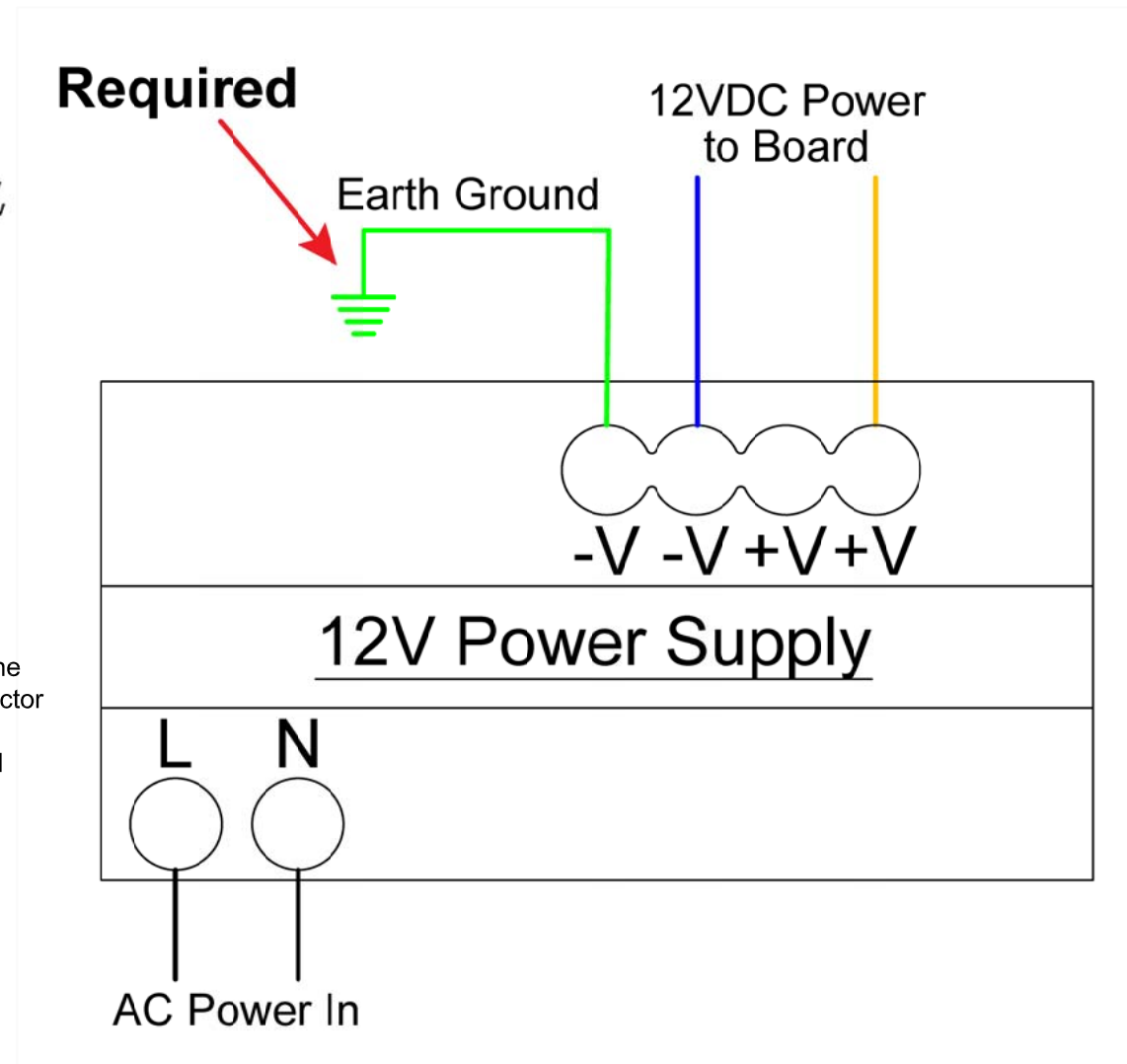

Back of MCS-TOUCH-15.4IN with Cover removed

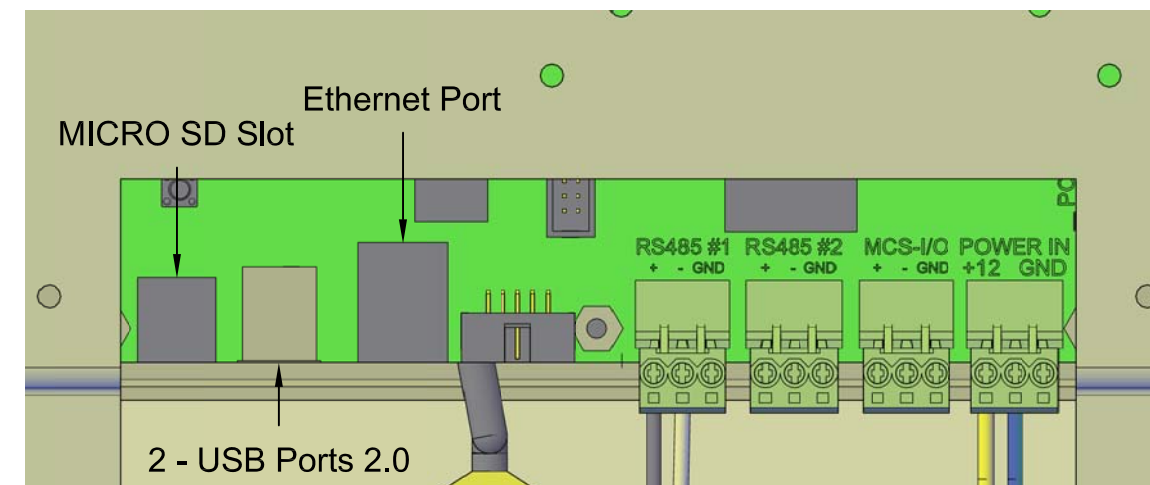

MCS-TOUCH-15.4IN-D

Ethernet-Switch Wiring Drawing

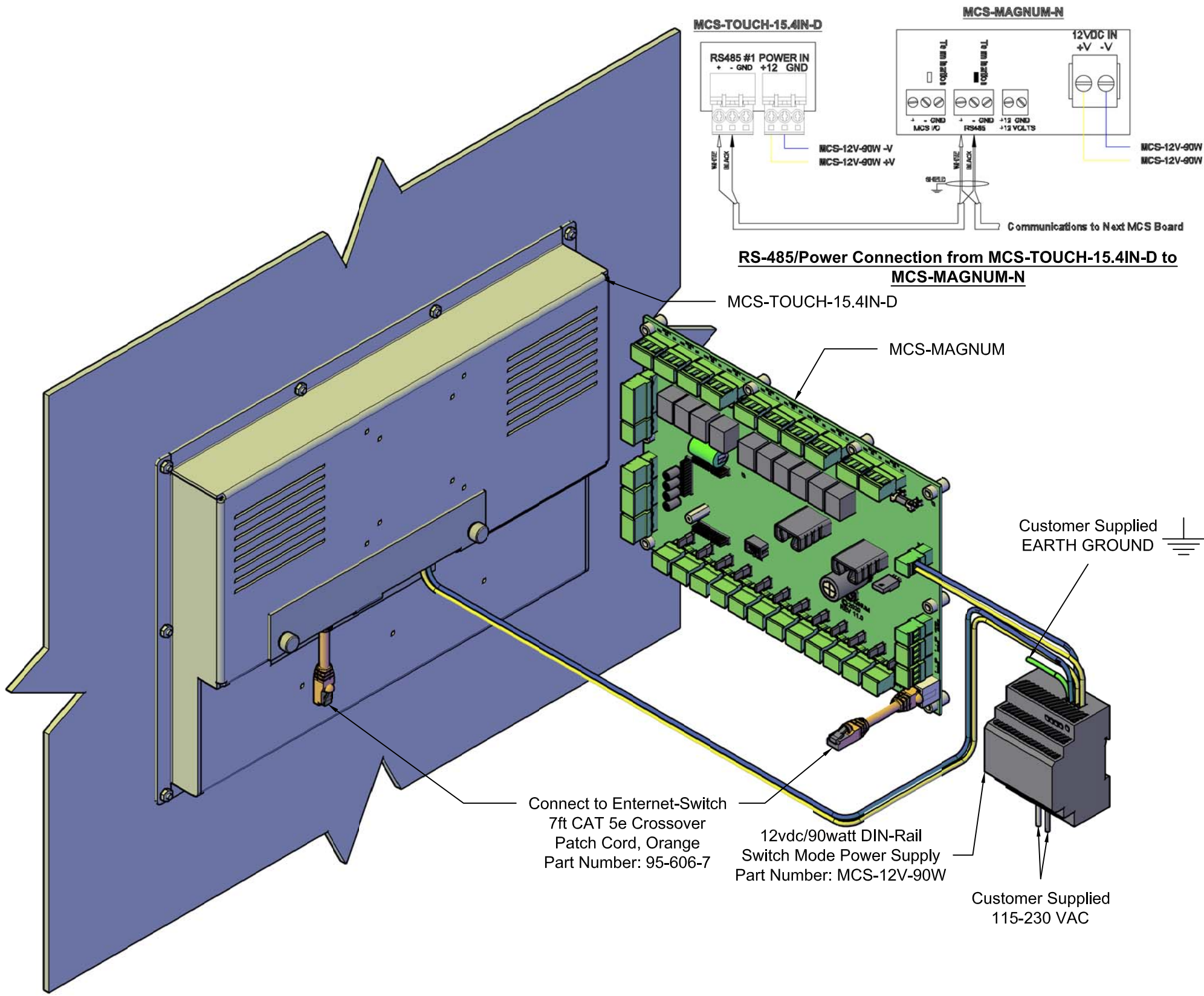

MCS-12V-90W Wiring Diagram

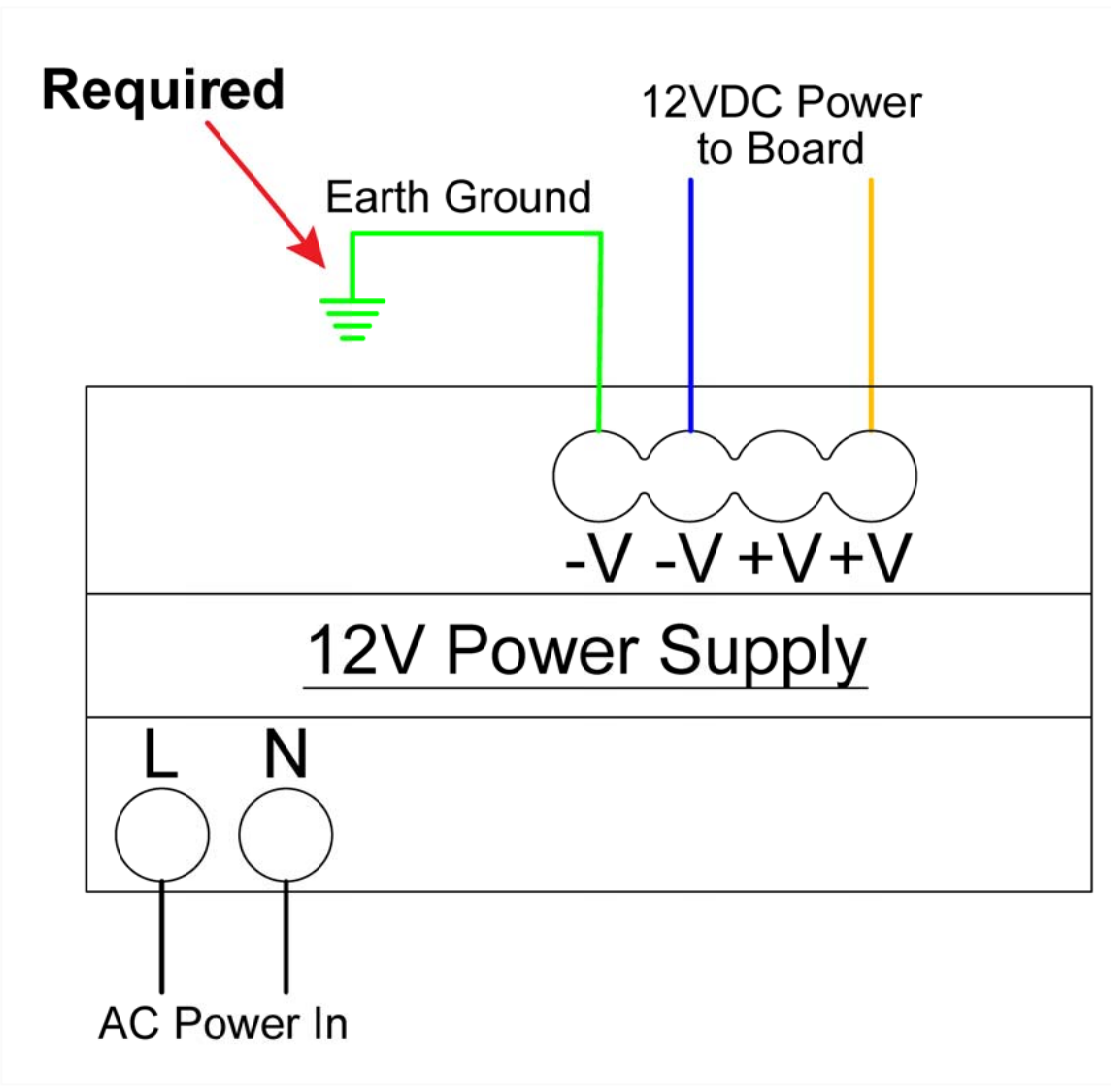

Back of MCS-TOUCH-15.4IN with Cover removed

